

DOCK EDGE ^{INC.} Premium & Ultimate

Howell™ Economy

MOORING WHIP INSTALLATION INSTRUCTIONS

IMPORTANT



CAUTION

Warning: Failure to follow proper installation instructions voids warranty and may lead to product failure and/or property damage.

Note: Some mooring areas may be too rough for any type of tie-up system.

IMPORTANT NOTES TO ENSURE A SAFE, SECURE INSTALLATION & WARRANT YOUR NEW MOORING WHIPS

IMPORTANT: Ensure that you have purchased the appropriate DockEdge Mooring Whip for your application. Weight and water level variations are more critical factors than length in estimating your requirements.

3 YEAR Limited Warranty
against defects in materials and workmanship.

MOORING WHIP PRODUCT CHART "A"

PREMIUM & ULTIMATE WHIP MODELS:

#3200 8 ft. (2.44m)	Craft Up to 18 ft. (5.49m) Up to 2,500 lb. (1133Kg) Capacity Mooring Distance From Dock - Minimum 3 Ft. (0.91m)
#3400 & 3450 12 ft. (3.66m)	Craft Up to 23 ft. (7.01m) Up to 5,000 lb. (2267Kg) Capacity Mooring Distance From Dock - Minimum 4 Ft. (1.22m)
#3600 & 3650 14 ft. (4.27m)	Craft Up to 28 ft. (8.53m) Up to 10,000 lb. (4535Kg) Capacity Mooring Distance From Dock - Minimum 5 Ft. (1.52m)
#3800 & 3850 16 ft. (4.88m)	Craft Up to 33 ft. (10.06m) Up to 20,000 lb. (9070Kg) Capacity Mooring Distance From Dock - Min. 5-6 Ft. (1.52-1.83m)

ECONOMY WHIP MODELS:

#3100 8 ft. (2.44m)	Craft Up to 18 ft. (5.49m) Up to 2,000 lb. (907Kg) Capacity Mooring Distance From Dock - Minimum 3 Ft. (0.91m)
#3120 12 ft. (3.66m)	Craft Up to 23 ft. (7.01m) Up to 4,000 lb. (1814Kg) Capacity Mooring Distance From Dock - Minimum 4 Ft. (1.22m) (supplied epoxy use required for assembly)

DOCK EDGE ^{INC.} Premium & Ultimate

1 INSTALLING THE MOORING WHIP BASES

Mooring whips require a firm, secure footing for mounting.

- The recommended location for mooring whips is on the side of the dock which is most protected from winds. This is preferable to cause the boat to stay clear of the dock rather than be forced towards it.
- Locate the cast aluminum bases 4-5" from the edge of the dock. Fig. 1a & 1b
- Align the whip bases with their respective cleats on the bow and stern of the boat making sure that the whips are perpendicular to the edge of the dock. Fig. 1c

The general rule is that the span between the whips should be approximately 2/3 of the boats' overall length. Install additional cleat(s) on the boat if necessary to retain the 2/3 rule. Space whip bases accordingly for such an application.

ATTENTION: Fig. 1b also illustrates the location of a bolt at the rear of the rocker base which is used to adjust the freeplay of a completed whip assembly. This bolt should be adjusted only enough to eliminate any freeplay between the rocker base arm and the rubber bushing.

NOTE: In applications where side cleats are unavailable a center bow or stern cleat of the boat may be used.

- Mark the location of the mounting holes for the bases and drill through the plank with a 1/8" drill bit. Lag down the whip bases with the lag bolts and washers supplied.

NOTE: Concrete docks will require lag bolts and masonry plug inserts. Softwood docks such as cedar should have a 3/8" hole drilled through the dock at each mounting hole location of the base and 3/8" bolts or "carriage" bolts and use washers, lock-washers and nuts or locking nuts in place of the 3/8" lag bolts supplied with your mooring whip kit.

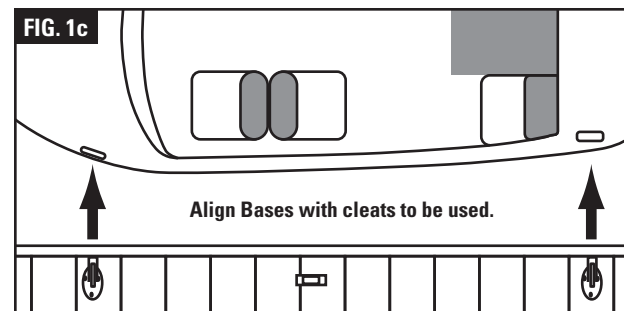
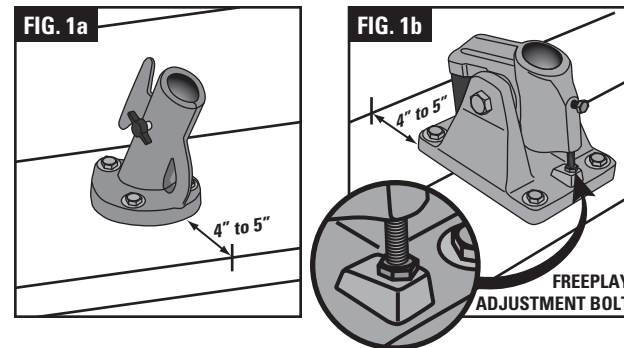

2 WHIP ASSEMBLY (where applicable)

Models 3400, 3450, 3600, 3650, 3800 & 3850 are two part assemblies. Carefully follow the instructions for 2-part assemblies. (See Fig. 2) With a threading motion turn the top portion of the mooring whip into the base section until it is fully seated.

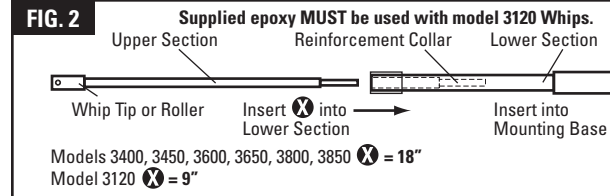

3 WHIP MOUNTING & PREPARATION

- Feed the whip lines over the line rollers at the tips. Ensure whip tip rollers are parallel to the dock surface. (Fig. 3)
- Insert the whip into the base, making sure the whip is fully seated in the base and so that the whip line is hanging straight down OR for models incorporating a tip pulley, align the pulley so that it is perpendicular to the dock surface. (Fig. 3)



Whip tip & roller pin assembly is ready for use. Optional wheel (not included with economy models) may be installed at the users discretion.

Once the tip has been aligned, tighten the thumb screw on the whip base only enough to prevent the whip from lifting out of the base. Overtightening may damage the fiberglass strand and integrity of the whip.

Pole Cleat - Attach the pole cleat no more than 14 inches from the whip base. See Fig. 4. The pole cleat can be used to wrap the boats' whip line around for quick release and ease of maneuvering the watercraft towards the dock when required.

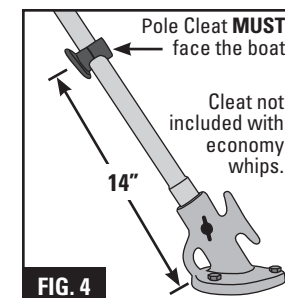

4 INSTALLATION OF WHIP LINES

- Tie off the dock side end of each whip line to the pole or base cleat, Fig. 4 making sure there is sufficient excess line at both ends to allow for tie-up of the boat with the tensioner, and release of line tension at the dock.
- To adjust for proper tension on the mooring whip lines slip the loops from the lines through the bow and stern cleats of the boat. Using the sliding tension adjuster, place enough tension on the line to just pull the whip tip down. (See Fig. 5 & 6)

CAUTION: When adjusting whip and/or spring line tensions DO NOT over-torque the whip. Pull each whip tip down in inches, as the whip is in total length, ie. 8ft. - 8 inches, 12 ft. - 12 inches, 14 ft. - 14 inches, 16 ft. - 16 inches.

CAUTION: For installation of mooring whips on stationary docks in locations where water levels fluctuate more than 2 ft., mooring whips without a rocker base MUST be adjusted periodically to compensate for these variations. Failure to make adjustments to spring and whip line tension in such conditions may result in damage to the whips and void the manufacturers warranty, see Fig. 5 thru 9. Adjustments are seldom necessary on floating docks, as the dock and boat will rise and fall accordingly. Alternatively, Mooring whips with a rocker base (models 3450, 3650 & 3850) may be installed for such applications. The rocker base should adequately adjust for tidal variations that could exceed the abilities of whips with a rigid non-pivoting base.

CORRECT INSTALLATION

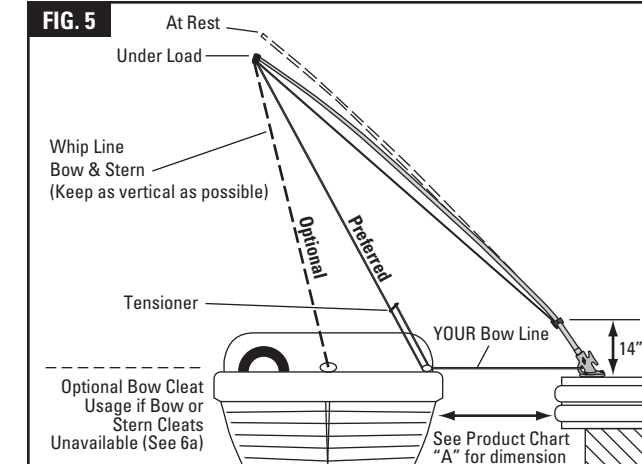

INCORRECT INSTALLATIONS

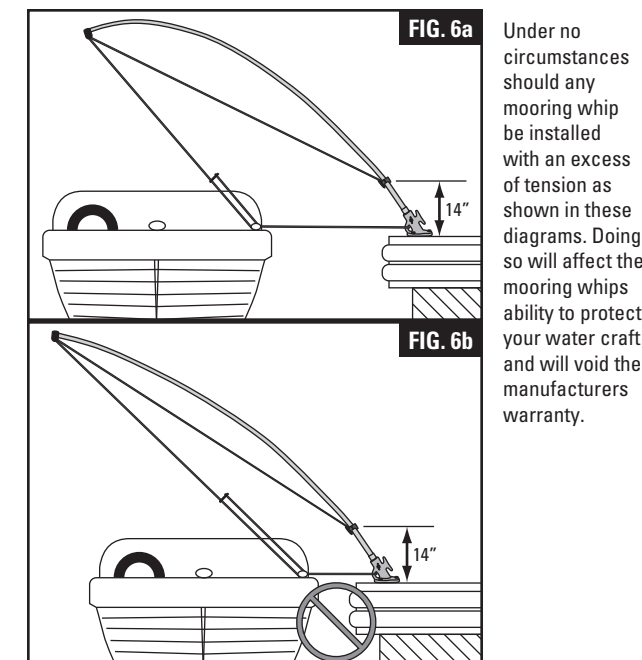

Under no circumstances should any mooring whip be installed with an excess of tension as shown in these diagrams. Doing so will affect the mooring whips ability to protect your water craft and will void the manufacturers warranty.

5 INSTALLATION OF SPRING LINES

- Refer to the Figures 5 through 9 for proper configuration and spring line attachment.
- Spring lines should be attached to the built-in cleat of solid mooring whip bases and bow and stern lines should be attached to the integral eyelet of each whip base. Pivoting/ rocker base whip bases must use separate dock cleats as shown in Fig. 7, 8 & 9.

IMPORTANT: Spring lines MUST always be used. Tension must be equal on all lines. Install additional cleat(s) on the boat if necessary to retain the 2/3 rule Discussed in Section 1 "Installing The Mooring Whip Bases".

The boat should lie the distance specified in product chart "A" for your whips.

DO NOT attempt to retain the "Distance from Dock" dimension shown in chart "A" if using oversized whips. Larger whips are intended for larger watercraft with a wider beam and therefore able to retain the recommended "Distance from Dock" dimension. Distance from dock should never be less than 3-4ft.

"M" Method - Whips & Whip Lines Not Shown

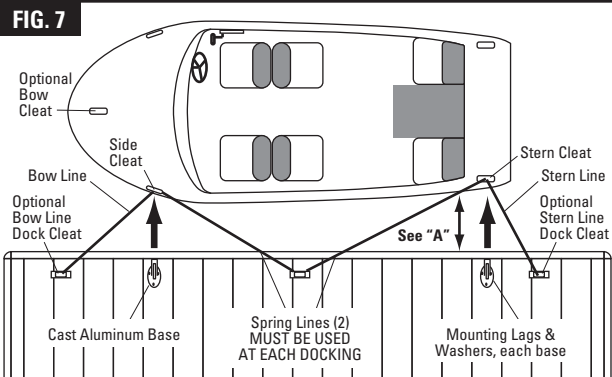

"X" Method - Whips & Whip Lines Not Shown

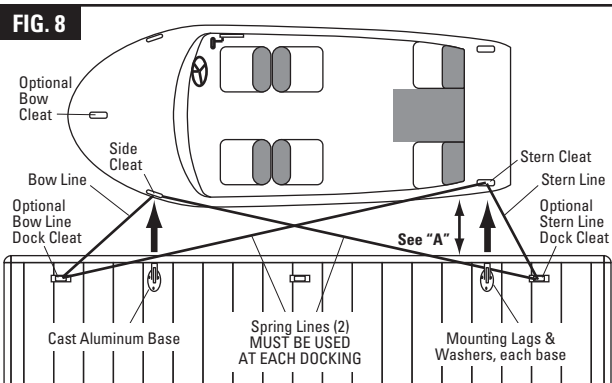

"V" Method - Whips & Whip Lines Not Shown

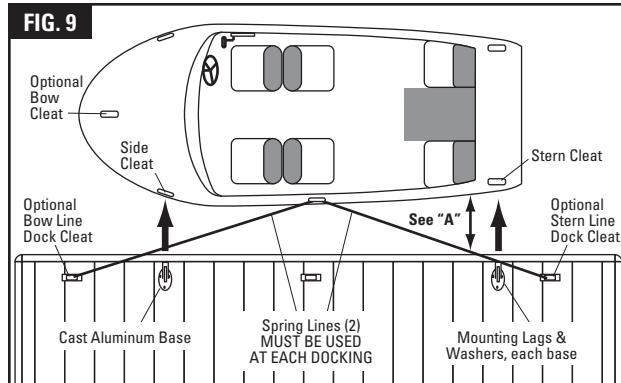

- Loops in the ends of the bow, stern and spring lines can be made using a "bowline knot" as shown in Fig. 10.
- Once the bow, stern and spring lines have been made to the correct length they should be left on the dock for easy tie-up upon return.

FIG. 10 BOWLINE KNOT

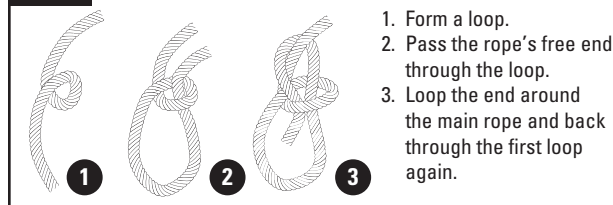

IMPORTANT: When spring lines have been cut to length, seal the cut ends of the lines with a flame (lighter, match or small torch) to prevent fraying.

WINTER STORAGE: For winter storage remove the whips from the aluminum bases only. Leave the aluminum bases mounted to the dock. Two (2) piece whip assemblies other than the DockEdge 3120 model, can be separated into the upper and lower halves for more compact storage. It is recommended that whips be stored in a location that remains above freezing such as a basement or heated garage.

Premium Whip kit includes:

- 2 whip poles
- 2 locking screws (for base)
- 2 pole cleat assembly (2pc)
- 2 optional pulley tip wheel
- 2 whip lines
- 1 spring line
- 2 line tensioners
- 2 aluminum bases
- 6 lag bolts (for bases)
- 6 washers (for bases)

Ultimate Whip kit includes:

- 2 whip poles
- 2 pole cleat assembly (2pc)
- 2 optional pulley tip wheel
- 2 whip lines
- 1 spring line
- 2 line tensioners
- 2 rocker bases
- 8 lag bolts (for bases)
- 8 washers (for bases)

For answers to your questions or to enquire about other DockEdge+ products call, write or visit us at:

DOCK EDGE  **INC.** 300 New Huntington Road
Woodbridge, ON, Canada L4H 0R4
CMP Phone: 800-295-3625 www.dockedge.com



Economy Whips

CAUTION: Installation of mooring whips on stationary docks where water levels fluctuate more than 2 ft.:

Mooring whips with a fixed angle base **MUST** be adjusted periodically to compensate for these variations. Failure to make adjustments to spring and whip line tension in such conditions may result in damage to the whips and void the manufacturers warranty, see Fig. 5 thru 9. Adjustments are seldom necessary on floating docks, as the dock and boat will rise and fall together accordingly.

1 INSTALLING THE MOORING WHIP BASES

Mooring whips require a firm, secure footing for mounting.

- The recommended location for mooring whips is on the side of the dock which is most protected from winds. This is preferable to cause the boat to stay clear of the dock rather than be forced towards it.
- Locate the aluminum bases 4-5" from the edge of the dock. Fig. 1a
- Align the whip bases with their respective cleats on the bow and stern of the boat making sure that the whips are perpendicular to the edge of the dock. Fig. 1c

The general rule is that the span between the whips should be approximately 2/3 of the boats' overall length. Install additional cleat(s) on the boat if necessary to retain the 2/3 rule. Space whip bases accordingly for such an application.

NOTE: In applications where side cleats are unavailable a center bow or stern cleat of the boat may be used.

- Mark the location of the mounting holes for the bases and drill through the plank with a 1/8" drill bit. Lag down the whip bases with the lag bolts and washers supplied.

NOTE: Concrete docks will require lag bolts and masonry plug inserts. Softwood docks such as cedar should have a 3/8" hole drilled through the dock at each mounting hole location of the base and 3/8" bolts or "carriage" bolts and use washers, lock-washers and nuts or locking nuts in place of the 3/8" lag bolts supplied with your mooring whip kit.

2 WHIP ASSEMBLY (where applicable)

Carefully follow the instructions for 2-part assemblies. (See Fig. 2). Supplied epoxy **MUST** be used with Howell 3120 Whips only. Ensure the 2-part epoxy is thoroughly mixed as it is applied. With a threading motion turn the top portion of the mooring whip into the base section until it is fully seated. Recommended cure time is 2 - 4 hours.

3 WHIP MOUNTING & PREPARATION

- Feed the whip lines through the whip line roller pins at the tips.
- Insert the whip into the base, making sure the whip is fully seated in the base and so that the whip line is hanging straight down. Ensure roller pins are parallel to the dock surface. See (Fig. 3)

Once the tip has been aligned, tighten the thumb screw on the whip base only enough to prevent the whip from lifting out of the base. Overtightening may damage the fiberglass strand and integrity of the whip.

4 INSTALLATION OF WHIP LINES

- Tie off the dock side end of each whip line to the pole or base cleat, making sure there is sufficient excess line at both ends to allow for tie-up of the boat with the tensioner, and release of line tension at the dock.
- To adjust for proper tension on the mooring whip lines slip the loops from the lines through the bow and stern cleats of the boat. Using the sliding tension adjuster, place enough tension on the line to just pull the whip tip down. (See Fig. 5 & 6)

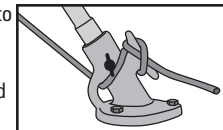

Sample Base Cleat Tie-Off

CAUTION: When adjusting whip and/ or spring line tensions Do Not over-torque the whip. Pull each whip tip down in inches, as the whip is in total length, ie. 8ft. - 8 inches, 12 ft. - 12 inches.

CAUTION: For installation of mooring whips on stationary docks in locations where water levels fluctuate more than 2 ft., fixed base whips **MUST** be adjusted periodically to compensate for these variations. Failure to make adjustments to spring and whip line tension in such conditions may result in damage to the whips and void the manufacturers warranty, see Fig. 5 thru 9.

5 INSTALLATION OF SPRING LINES

- Refer to the illustrations below for proper configuration and spring line attachment.
- Spring lines should be attached to the built-in cleat of solid mooring whip bases and bow and stern lines should be attached to the integral eyelet of each whip base. Pivoting/ rocker base whip bases must use separate dock cleats as shown in Fig. 7, 8 & 9.

IMPORTANT: Spring lines **MUST** always be used. Tension must be equal on all lines. Install additional cleat(s) on the boat if necessary to retain the 2/3 rule discussed in the Section 1.

The boat should lie the distance specified in product chart "A" (page 1) from and parallel to the dock.

DO NOT attempt to retain the "Distance from Dock" dimension shown in chart "A" (page 1) if using oversized whips. Larger whips are intended for larger watercraft with a wider beam and therefore able to retain the recommended "Distance from Dock" dimension.

Distance from dock should never be less than 3-4ft.

- Loops in the ends of the bow, stern and spring lines can be made using a "bowline knot" as shown in Fig. 10.
- Once the bow, stern and spring lines have been made to the correct length they should be left on the dock for easy tie-up upon return.

IMPORTANT: When spring lines have been cut to length, seal the cut ends of the lines with a flame (lighter, match or small torch) to prevent fraying.

WINTER STORAGE: For winter storage remove the whips from the aluminum bases only. Leave the aluminum bases mounted to the dock. It is recommended that whips be stored in a location that remains above freezing such as a basement or heated garage.

Economy Whip kit includes:

- | | | |
|------------------------------|--------------------------------|---------------|
| 2 whip poles | 2 whip lines | 1 Spring line |
| 2 line tensioners | 2 aluminum bases | |
| 2 locking screws (for bases) | 6 lag bolts (for bases) | |
| 6 washers (for bases) | 1 epoxy glue for (3120-F only) | |